



Linde Material Handling

Linde



Electric Counterbalance Trucks

E35 – E50

Capacity 7,700 - 11,000 lb. | Series 1254

Zero-emissions powerhouse

- Versatile application thanks to wide variety of models, broad range of standard equipment and extensive range of options
- Linde combi steer axle and twin motor front-wheel drive for outstanding manoeuvrability even in tight spaces
- Twin or single pedal control and Linde Load Control for precise, fatigue-free load handling
- Smooth operation, outstanding visibility and wide range of safety options
- Available with lead-acid or lithium-ion battery

STANDARD & OPTIONAL EQUIPMENT

	Model/Equipment	E35 - E50
Workplace	Innovative isolation concept featuring ring bearings between chassis and drive axle for minimal human vibrations	●
	Ergonomic and safe on/off access due to low non-slip step and handles on the A-pillar and battery cover	●
	Comfort overhead guard for maximum headroom	●
	Fully integrated, powerful heating/air conditioning incl. defrost	○
	Operator's seat - quick, easy mechanical weight adjustment	●
	Different operator's seat options: heated seats, air suspension, fore/aft suspension, swivelling seat	○
	Steering column with tilt adjustment	○
	3.5" LED colour display with steering angle and tilt angle display	●
	7" LED multifunction colour display	○
	Armoured glass top screen	○
Metal doors with wide-opening window	○	
Drive and Brake System	Twin motor front-wheel drive with electronic traction control	●
	Synchronous Reluctance Motors (SRM) for maximum efficiency in traction and lifting functions	●
	Choice of operating settings - economy, efficiency and performance - for individual performance adjustment	●
	Automatic parking brake	●
Axles and Tires	Linde combi steering axle - optimum manoeuvrability in the tightest spaces	●
	Super-Elastic (SE) tires	●
	Closed shoulder (CS 20) tires	○
	Non-marking SE tires with anti-static strap	○
	Dirt deflectors/mud guards, front and rear	○
Mast	High mounted tilt cylinders with maintenance-free bearings	●
	Optimum visibility due to asymmetric nested mast profiles on standard, duplex and triplex masts	●
	Electronically damped tilt stop	●
	Load damping for high degree of driving comfort and load protection	○
Attachment /Forks	Roller-guided integral side shift carriage provides full nominal load capacity	○
	Integral fork positioner "VIEW" for high residual load capacity and optimum visibility	○
Assistance	Linde Curve Assist - automatic reduction of travel speed around corners	●
	Linde Load Assist - active intervention in forward tilt and lift speed increases safety at high lift heights	●
	Electrical safety belt and/or door monitoring	●
	Linde Guardian - warning between trucks, trucks/pedestrians and zone-dependent driving speeds	○
	Reverse Assist Camera	○
	BlueSpot and TruckSpot - visual drive path warning for pedestrians, operators and the environment	○
	Wide choice of lighting options: Headlights, LED light strips, VertiLights	○
Digitalisation	Online data transmission	●
	WiFi data transmission	○
	Linde connect:desk - local fleet management with different functional modules	○
	Pre-Operation Check App - customisable daily inspection log to check the readiness of the truck for operation	○
Operation/Load Handling	Twin pedal control - smooth acceleration and quick direction changes	●
	Single pedal control - smooth acceleration	○
	Individual electronic lever control of hydraulic functions	●
	Single, double and triple ancillary hydraulics	○
	Linde Steer Control - ergonomic steering concept integrated into the left armrest for enhanced forward visibility	○
Energy	Easy lateral battery changing from the side and hinged battery cover for daily checking of the lead-acid battery	●
	Li-ION ready	●
	Flexible, simple charging options with convenient rear charging socket	○

● Standard equipment ○ Optional equipment

E35 - E50 TECHNICAL DATA

	E35/600H			E40/600H			E40/600HL		
	Manufacturer		LINDE	LINDE	LINDE	LINDE	LINDE	LINDE	LINDE
Characteristics	1.1	Manufacturer		LINDE	LINDE	LINDE	LINDE	LINDE	LINDE
	1.2	Manufacturer type designation		E35/600H	E40/600H	E40/600HL	E35/600H	E40/600H	E40/600HL
	1.2a	Series		1254	1254	1254	1254	1254	1254
	1.3	Drive system		Battery	Battery	Battery	Battery	Battery	Battery
	1.4	Operator type		Seat	Seat	Seat	Seat	Seat	Seat
	1.5	Rated capacity/rated load	Q (lb)	7,700	8,800	8,800	7,700	8,800	8,800
	1.6	Load center distance	c (in)	24	24	24	24	24	24
	1.8	Load distance, center of drive axle to fork	x (in)	19.7	20.1	20.1	19.7	20.1	20.1
	1.9	Wheelbase	y (in)	75.8	75.8	75.8	75.8	81.5	81.5
Weights	2.1	Service weight	lb	14,742 ¹⁾	15,505 ¹⁾	15,635 ¹⁾	14,742	15,505	15,635
	2.2	Axle loading, loaded front/rear	lb	19,934 / 2,524	21,836 / 2,486	21,863 / 2,590	19,934	21,836	21,863
	2.3	Axle loading, unloaded front/rear	lb	7,808 / 6,933	7,932 / 7,572	8,315 / 7,319	7,808	7,932	8,315
Wheels/Tyres	3.1	Tire type		Solid-pneumatic	Solid-pneumatic	Solid-pneumatic	Solid-pneumatic	Solid-pneumatic	Solid-pneumatic
	3.2	Tire size, front		355/50-15	355/50-15	355/50-15	355/50-15	355/50-15	355/50-15
	3.3	Tire size, rear		225/75-10 (23x9-10)	225/75-10 (23x9-10)	225/75-10 (23x9-10)	225/75-10 (23x9-10)	225/75-10 (23x9-10)	225/75-10 (23x9-10)
	3.5	Wheels, number front/rear (x = driven wheels)		2x / 2	2x / 2	2x / 2	2x / 2	2x / 2	2x / 2
	3.6	Tread, front	b10 (in)	45.6	45.6	45.6	45.6	45.6	45.6
3.7	Tread, rear	b11 (in)	42.6	42.6	42.6	42.6	42.6	42.6	
Dimensions	4.1	Tilt range, forward/backward	α/β (°)	See table	See table	See table	See table	See table	See table
	4.2	Height of mast, lowered	h1 (in)	See table	See table	See table	See table	See table	See table
	4.3	Free lift	h2 (in)	See table	See table	See table	See table	See table	See table
	4.4	Lift	h3 (in)	See table	See table	See table	See table	See table	See table
	4.5	Height, mast extended	h4 (in)	See table	See table	See table	See table	See table	See table
	4.7	Height of overhead guard (cabin)	h6 (in)	95.1	95.1	95.1	95.1	95.1	95.1
	4.8	Seat height	h7 (in)	50.9	50.9	50.9	50.9	50.9	50.9
	4.12	Coupling height	h10 (in)	26.7	26.6	26.6	26.7	26.6	26.6
	4.19	Overall length	l1 (in)	157.3	157.3	162.2	157.3	157.3	162.2
	4.20	Length to face of forks	l2 (in)	109.3	109.3	114.2	109.3	109.3	114.2
	4.21	Overall width	b1/b2 (in)	57.2	57.2	57.2	57.2	57.2	57.2
	4.22	Fork dimensions	s / e / l (in)	2.0 x 5.0 x 48	2.0 x 5.0 x 48	2.0 x 5.0 x 48	2.0 x 5.0 x 48	2.0 x 5.0 x 48	2.0 x 5.0 x 48
	4.23	Fork carriage ISO 2328, class/type A, B		3A	3A	3A	3A	3A	3A
	4.24	Fork carriage width	b3 (in)	53.2	53.2	53.2	53.2	53.2	53.2
	4.31	Ground clearance, loaded, below mast	m1 (in)	6.3	6.3	6.3	6.3	6.3	6.3
	4.32	Ground clearance, center of wheelbase	m2 (in)	6.4	6.3	6.3	6.4	6.3	6.3
4.34	Aisle width for pallets 40" x 48"	Ast (in)	168	168	173	168	168	173	
4.35	Turning radius	Wa (in)	89	89	94	89	89	94	
4.36	Internal turning radius	b13 (in)	0	0	0	0	0	0	
Performance	5.1	Travel speed, loaded/unloaded	mph	12.4 / 12.4	12.4 / 12.4	12.4 / 12.4	12.4 / 12.4	12.4 / 12.4	12.4 / 12.4
	5.2	Lift speed, loaded/unloaded	fpm	100 / 108	92 / 108	92 / 108	100 / 108	92 / 108	92 / 108
	5.3	Lowering speed, loaded/unloaded	fpm	106 / 108	108 / 108	108 / 108	106 / 108	108 / 108	108 / 108
	5.5	Drawbar pull, loaded/unloaded	lbf	1,461 / 1,461	1,461 / 1,461	1,461 / 1,461	1,461 / 1,461	1,461 / 1,461	1,461 / 1,461
	5.6	Max. drawbar pull, loaded/unloaded	lbf	4,271 / 4,271	4,271 / 4,271	4,271 / 4,271	4,271 / 4,271	4,271 / 4,271	4,271 / 4,271
	5.7	Gradeability, loaded/unloaded	%	11 / 19	10 / 18	10 / 17	11 / 19	10 / 18	10 / 17
	5.8	Max. gradeability, loaded/unloaded	%	19 / 31	17 / 29	17 / 29	19 / 31	17 / 29	17 / 29
	5.9	Acceleration time, loaded/unloaded	s	5.7 / 5.0	5.9 / 5.0	5.9 / 5.1	5.7 / 5.0	5.9 / 5.0	5.9 / 5.1
	5.10	Service brake		hydr./mech.	hydr./mech.	hydr./mech.	hydr./mech.	hydr./mech.	hydr./mech.
	Drive	6.1	Drive motor rating S2 60 min	kW	2 x 12.5	3 x 12.5	4 x 12.5	2 x 12.5	3 x 12.5
6.2		Lift motor rating at S3 15%	kW	28	28	28	28	28	28
6.3		Maximum battery dimensions	x / y / z (in)	40.5 x 33.7 x 30.9	40.5 x 33.7 x 30.9	40.5 x 39.3 x 30.9	40.5 x 33.7 x 30.9	40.5 x 33.7 x 30.9	40.5 x 39.3 x 30.9
6.4a		Battery specification (European DIN 43536)	Type / V / Ah	5PzS / 80 / 775	5PzS / 80 / 775	6PzS / 80 / 930	5PzS / 80 / 775	5PzS / 80 / 775	6PzS / 80 / 930
6.4b		Battery specification (lead-acid; 6h/North America)	V / Ah	80 / 625	80 / 625	80 / 750	80 / 625	80 / 625	80 / 750
6.4c		Battery specification (Linde Li-ION, Size M)	V / kWh	-	-	90 / 65.9	-	-	90 / 65.9
6.5		Battery weight (\pm 5%)	lb	4,107	4,107	4,802	4,107	4,107	4,802
6.7	CO2 equivalent according to DIN EN 16796	lb/hr	10.1	10.7	10.9	10.1	10.7	10.9	
Others	10.1	Operating pressure for attachments	psi	2,470	2,470	2,470	2,470	2,470	2,470
	10.2	Oil volume for attachments	gpm	14.5	14.5	14.5	14.5	14.5	14.5
	10.7	Sound pressure level LpAZ (at the driver's seat)	dB(A)	67	67	67	67	67	67

1) Figures with battery

2) Including 8" operating aisle clearance.

E35 - E50 TECHNICAL DATA

Characteristics	1.1	Manufacturer		LINDE	LINDE	LINDE	LINDE
	1.2	Manufacturer type designation		E45/600H	E45/600HL	E50/500HL	E50/600HL
	1.2a	Series		1254	1254	1254	1254
	1.3	Drive system		Battery	Battery	Battery	Battery
	1.4	Operator type		Seat	Seat	Seat	Seat
	1.5	Rated capacity/rated load	Q (lb)	9,900	9,900	10,000	11,000
	1.6	Load center distance	c (in)	24	24	24	24
	1.8	Load distance, center of drive axle to fork	x (in)	20.1	20.1	20.1	20.1
	1.9	Wheelbase	y (in)	75.8	81.5	81.5	81.5
Weights	2.1	Service weight	lb	16,561 ¹⁾	16,391 ¹⁾	16,340 ¹⁾	17,317 ¹⁾
	2.2	Axle loading, loaded front/rear	lb	23,649 / 2,832	23,593 / 2,718	24,636 / 2,705	25,287 / 3,031
	2.3	Axle loading, unloaded front/rear	lb	8,007 / 8,553	8,353 / 8,038	8,267 / 8,073	8,386 / 8,930
Wheels/Tyres	3.1	Tire type		Solid-pneumatic	Solid-pneumatic	Solid-pneumatic	Solid-pneumatic
	3.2	Tire size, front		355/50-15	355/50-15	355/50-15	355/50-15
	3.3	Tire size, rear		225/75-10 (23x9-10)	225/75-10 (23x9-10)	225/75-10 (23x9-10)	225/75-10 (23x9-10)
	3.5	Wheels, number front/rear (x = driven wheels)		2x / 2	2x / 2	2x / 2	2x / 2
	3.6	Tread, front	b10 (in)	45.6	45.6	45.6	45.6
	3.7	Tread, rear	b11 (in)	42.6	42.6	42.6	42.6
	Dimensions	4.1	Tilt range, forward/backward	α/β (°)	See table	See table	See table
4.2		Height of mast, lowered	h1 (in)	See table	See table	See table	See table
4.3		Free lift	h2 (in)	See table	See table	See table	See table
4.4		Lift	h3 (in)	See table	See table	See table	See table
4.5		Height, mast extended	h4 (in)	See table	See table	See table	See table
4.7		Height of overhead guard (cabin)	h6 (in)	95.1	95.1	95.1	95.1
4.8		Seat height	h7 (in)	50.9	50.9	50.9	50.9
4.12		Coupling height	h10 (in)	26.6	26.6	26.6	26.5
4.19		Overall length	l1 (in)	157.3	162.2	162.2	163
4.20		Length to face of forks	l2 (in)	109.3	114.2	114.2	115
4.21		Overall width	b1/b2 (in)	57.2	57.2	57.2	57.2
4.22		Fork dimensions	s / e / l (in)	2.0 x 5.0 x 48	2.0 x 5.0 x 48	2.0 x 5.0 x 48	2.0 x 5.0 x 48
4.23		Fork carriage ISO 2328, class/type A, B		3A	3A	3A	3A
4.24		Fork carriage width	b3 (in)	53.2	53.2	53.2	53.2
4.31		Ground clearance, loaded, below mast	m1 (in)	6.2	6.2	6.2	6.2
4.32		Ground clearance, center of wheelbase	m2 (in)	6.3	6.3	6.3	6.3
4.34		Aisle width for pallets 40" x 48"	Ast (in)	168	173	173	174
4.35		Turning radius	Wa (in)	89	94	94	95
4.36	Internal turning radius	b13 (in)	0	0	0	0	
Performance	5.1	Travel speed, loaded/unloaded	mph	12.4 / 12.4	12.4 / 12.4	12.4 / 12.4	12.4 / 12.4
	5.2	Lift speed, loaded/unloaded	fpm	84 / 108	84 / 108	76 / 100	76 / 100
	5.3	Lowering speed, loaded/unloaded	fpm	108 / 108	108 / 108	106 / 110	106 / 110
	5.5	Drawbar pull, loaded/unloaded	lbf	1,461 / 1,461	1,461 / 1,461	1,461 / 1,461	1,461 / 1,461
	5.6	Max. drawbar pull, loaded/unloaded	lbf	4,271 / 4,271	4,271 / 4,271	4,271 / 4,271	4,271 / 4,271
	5.7	Gradeability, loaded/unloaded	%	9 / 16	9 / 16	9 / 17	9 / 15
	5.8	Max. gradeability, loaded/unloaded	%	15 / 27	16 / 27	15 / 27	14 / 25
	5.9	Acceleration time, loaded/unloaded	s	6.1 / 5.2	6.0 / 5.1	6.1 / 5.1	6.2 / 5.2
	5.10	Service brake		hydr./mech.	hydr./mech.	hydr./mech.	hydr./mech.
	Drive	6.1	Drive motor rating S2 60 min	kW	5 x 12.5	6 x 12.5	7 x 12.5
6.2		Lift motor rating at S3 15%	kW	28	28	28	28
6.3		Maximum battery dimensions	X / Y / Z (in)	40.5 x 33.7 x 30.9	40.5 x 39.3 x 30.9	40.5 x 39.3 x 30.9	40.5 x 39.3 x 30.9
6.4a		Battery specification (European DIN 43536)	Type / V / Ah	5PzS / 80 / 775	6PzS / 80 / 930	6PzS / 80 / 930	6PzS / 80 / 930
6.4b		Battery specification (lead-acid; 6h/North America)	V / Ah	80 / 625	80 / 750	80 / 750	80 / 750
6.4c		Battery specification (Linde Li-ION, Size M)	V / kWh	-	90 / 65.9	90 / 65.9	90 / 65.9
6.5		Battery weight (\pm 5%)	lb	4,107	4,802	4,802	4,802
6.7	CO2 equivalent according to DIN EN 16796	lb/hr	11.2	11.3	11.9	12.4	
Others	10.1	Operating pressure for attachments	psi	2,470	2,470	2,470	2,470
	10.2	Oil volume for attachments	gpm	14.5	14.5	14.5	14.5
	10.7	Sound pressure level LpAZ (at the driver's seat)	dB(A)	67	67	67	67

1) Figures with battery

2) Including 8" operating aisle clearance.

E35 - E50 TECHNICAL DATA

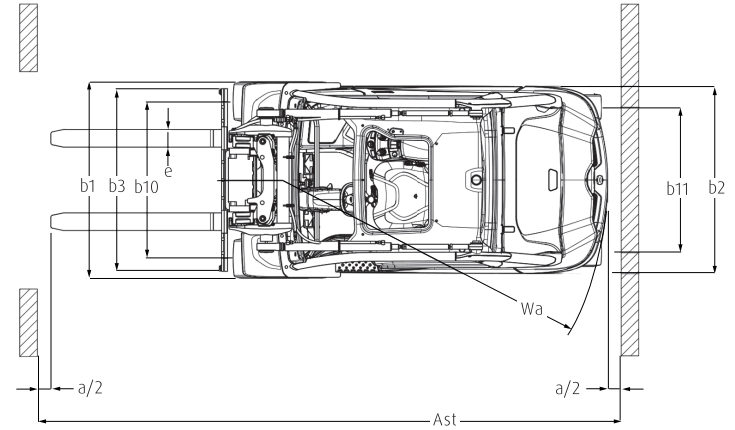
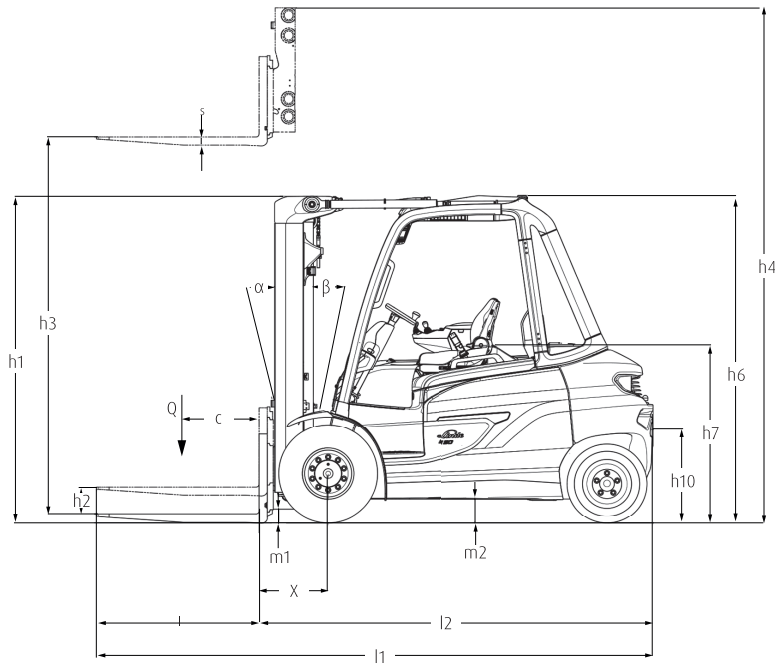

*Refer to Technical Data Chart

MAST TABLES

E35/600H

Capacity (lb) at 600mm / 24" load center

Type	h1 (in)	h3 (in)	h2 (in)	Tilt	Std. Carriage	Integrated Sideshifter	Hang-on Side-shifter	Integrated Sideshifting fork positioner
Standard	92.8	122.0	0.0	5F / 8B	7,700	7,700	7,525	7,375
	94.7	126.0	0.0	5F / 8B	7,700	7,700	7,525	7,375
	98.7	133.9	0.0	5F / 8B	7,700	7,700	7,525	7,375
	104.6	145.7	0.0	5F / 8B	7,700	7,700	7,525	7,375
	108.5	153.5	0.0	5F / 8B	7,700	7,700	7,525	7,375
	112.5	161.4	0.0	5F / 8B	7,700	7,700	7,525	7,375
Duplex	122.3	181.1	0.0	5F / 8B	7,700	7,700	7,525	7,375
	85.4	107.5	48.2	5F / 8B	7,700	7,700	7,525	7,375
	93.7	123.2	56.1	5F / 8B	7,700	7,700	7,525	7,375
	95.7	127.2	58.1	5F / 8B	7,700	7,700	7,525	7,375
	99.6	135.0	62.0	5F / 8B	7,700	7,700	7,525	7,375
	105.5	146.9	67.9	5F / 8B	7,700	7,700	7,525	7,375
Triplex	113.4	162.6	75.8	5F / 8B	7,700	7,700	7,525	7,375
	85.4	160.4	48.2	5F / 8B	7,700	7,700	7,525	7,375
	93.7	184.1	56.1	5F / 8B	7,700	7,700	7,525	7,375
	95.7	187.6	58.1	5F / 8B	7,700	7,700	7,525	7,375
	97.6	193.5	60.0	5F / 6B	7,700	7,700	7,525	7,375
	99.6	199.4	62.0	5F / 6B	7,700	7,700	7,525	7,375
	103.5	211.2	65.9	5F / 6B	7,700	7,700	7,525	7,375

MAST TABLES

E40/600H E40/600HL

Capacity (lb) at 600mm / 24" load center

Type	h1 (in)	h3 (in)	h2 (in)	Tilt	Std. Carriage	Integrated Sideshifter	Hang-on Side-shifter	Integrated Sideshifting fork positioner
Standard	92.8	122.0	0.0	5F / 8B	8,800	8,800	8,750	8,550
	94.7	126.0	0.0	5F / 8B	8,800	8,800	8,750	8,550
	98.7	133.9	0.0	5F / 8B	8,800	8,800	8,750	8,550
	104.6	145.7	0.0	5F / 8B	8,800	8,800	8,750	8,550
	108.5	153.5	0.0	5F / 8B	8,800	8,800	8,750	8,550
	112.5	161.4	0.0	5F / 8B	8,800	8,800	8,750	8,550
	122.3	181.1	0.0	5F / 8B	8,800	8,800	8,750	8,550
Duplex	85.4	107.5	48.2	5F / 8B	8,800	8,800	8,750	8,550
	93.7	123.2	56.1	5F / 8B	8,800	8,800	8,750	8,550
	95.7	127.2	58.1	5F / 8B	8,800	8,800	8,750	8,550
	99.6	135.0	62.0	5F / 8B	8,800	8,800	8,750	8,550
	105.5	146.9	67.9	5F / 8B	8,800	8,800	8,750	8,550
	113.4	162.6	75.8	5F / 8B	8,800	8,800	8,750	8,550
Triplex	85.4	160.4	48.2	5F / 8B	8,800	8,800	8,750	8,550
	93.7	184.1	56.1	5F / 8B	8,800	8,800	8,750	8,550
	95.7	187.6	58.1	5F / 8B	8,800	8,800	8,750	8,550
	97.6	193.5	60.0	5F / 6B	8,800	8,800	8,750	8,550
	99.6	199.4	62.0	5F / 6B	8,800	8,800	8,750	8,550
	103.5	211.2	65.9	5F / 6B	8,800	8,800	8,700	8,500

E45/600H E45/600HL

Capacity (lb) at 600mm / 24" load center

Type	h1 (in)	h3 (in)	h2 (in)	Tilt	Std. Carriage	Integrated Sideshifter	Hang-on Side-shifter	Integrated Sideshifting fork positioner
Standard	94.7	122.0	0.0	5F / 8B	9,900	9,900	9,775	9,625
	96.7	126.0	0.0	5F / 8B	9,900	9,900	9,775	9,625
	100.6	133.9	0.0	5F / 8B	9,900	9,900	9,775	9,625
	106.5	145.7	0.0	5F / 8B	9,900	9,900	9,775	9,625
	110.5	153.5	0.0	5F / 8B	9,900	9,900	9,775	9,625
	114.4	161.4	0.0	5F / 8B	9,900	9,900	9,775	9,625
	124.3	181.1	0.0	5F / 8B	9,900	9,900	9,775	9,625
Duplex	85.4	107.5	48.2	5F / 8B	9,900	9,900	9,775	9,625
	95.7	123.2	58.1	5F / 8B	9,900	9,900	9,775	9,625
	97.6	127.2	60.0	5F / 8B	9,900	9,900	9,775	9,625
	101.6	135.0	64.0	5F / 8B	9,900	9,900	9,775	9,625
	107.5	146.9	69.9	5F / 8B	9,900	9,900	9,775	9,625
	115.4	162.6	77.8	5F / 8B	9,900	9,900	9,775	9,625
Triplex	85.4	160.4	48.2	5F / 8B	9,900	9,900	9,775	9,625
	95.7	184.1	58.1	5F / 8B	9,900	9,900	9,775	9,625
	97.6	187.6	60.0	5F / 8B	9,900	9,900	9,775	9,625
	99.6	193.5	62.0	5F / 6B	9,900	9,900	9,775	9,625
	101.6	199.4	64.0	5F / 6B	9,900	9,900	9,775	9,625
	105.5	211.2	67.9	5F / 6B	9,900	9,900	9,775	9,550

MAST TABLES

E50HL

Capacity (lb) at 600mm / 24" load center

Type	h1 (in)	h3 (in)	h2 (in)	Tilt	Std. Carriage	Integrated Sideshifter	Hang-on Side-shifter	Integrated Sideshifting fork positioner
Standard	94.7	114.2	0.0	5F / 8B	10,000	10,000	9,850	9,625
	100.6	126.0	0.0	5F / 8B	10,000	10,000	9,850	9,625
	110.5	145.7	0.0	5F / 8B	10,000	10,000	9,850	9,625
	118.4	161.4	0.0	5F / 8B	10,000	10,000	9,850	9,625
	132.1	198.0	0.0	5F / 8B	10,000	10,000	9,850	9,625
Duplex	85.4	99.6	44.3	5F / 8B	10,000	10,000	9,850	9,625
	95.7	115.4	54.1	5F / 8B	10,000	10,000	9,850	9,625
	97.6	119.3	56.1	5F / 8B	10,000	10,000	9,850	9,625
	101.6	127.2	60.0	5F / 8B	10,000	10,000	9,850	9,625
	107.5	139.0	65.9	5F / 8B	10,000	10,000	9,850	9,625
Triplex	115.4	154.7	73.8	5F / 8B	10,000	10,000	9,850	9,625
	85.4	148.6	48.2	5F / 8B	10,000	10,000	9,850	9,625
	95.7	172.2	54.1	5F / 8B	10,000	10,000	9,850	9,625
	97.6	175.8	56.1	5F / 8B	10,000	10,000	9,850	9,625
	99.6	181.7	58.1	5F / 8B	10,000	10,000	9,850	9,625
	101.6	187.6	60.0	5F / 8B	10,000	10,000	9,850	9,625
	105.5	199.4	64.0	5F / 6B	10,000	10,000	9,850	9,625
107.5	205.3	65.9	5F / 6B	10,000	10,000	9,850	9,625	
	113.4	219.1	71.9	5F / 6B	10,000	10,000	9,400	9,200

E50/600HL

Capacity (lb) at 600mm / 24" load center

Type	h1 (in)	h3 (in)	h2 (in)	Tilt	Std. Carriage	Integrated Sideshifter	Hang-on Side-shifter	Integrated Sideshifting fork positioner
Standard	94.7	114.2	0.0	5F / 8B	11,000	11,000	10,000	10,600
	100.6	126.0	0.0	5F / 8B	11,000	11,000	10,000	10,600
	110.5	145.7	0.0	5F / 8B	11,000	11,000	10,000	10,600
	118.4	161.4	0.0	5F / 8B	11,000	11,000	10,000	10,600
	132.1	198.0	0.0	5F / 8B	11,000	11,000	10,000	10,600
Duplex	85.4	99.6	44.3	5F / 8B	11,000	11,000	10,000	10,600
	95.7	115.4	54.1	5F / 8B	11,000	11,000	10,000	10,600
	97.6	119.3	56.1	5F / 8B	11,000	11,000	10,000	10,600
	101.6	127.2	60.0	5F / 8B	11,000	11,000	10,000	10,600
	107.5	139.0	65.9	5F / 8B	11,000	11,000	10,000	10,600
Triplex	115.4	154.7	73.8	5F / 8B	11,000	11,000	10,000	10,600
	85.4	148.6	48.2	5F / 8B	11,000	11,000	10,000	10,600
	95.7	172.2	54.1	5F / 8B	11,000	11,000	10,000	10,600
	97.6	175.8	56.1	5F / 8B	11,000	11,000	10,000	10,600
	99.6	181.7	58.1	5F / 8B	11,000	11,000	10,000	10,600
	101.6	187.6	60.0	5F / 8B	11,000	11,000	10,000	10,600
	105.5	199.4	64.0	5F / 6B	11,000	11,000	10,000	10,600
107.5	205.3	65.9	5F / 6B	11,000	11,000	10,000	10,600	
	113.4	219.1	71.9	5F / 6B	10,386	10,225	10,000	9,800

CHARACTERISTICS



Panoramic view

Productivity

- Narrow mast profile and A-pillar for outstanding all-round visibility
- Linde Curve Assist automatically reduces speed when cornering
- Numerous optional assistance systems as well as many warning and light options



Operator's workplace

Ergonomics

- Spacious operator's compartment, various ergonomic seats and an isolated operator's workstation for exceptional operating comfort
- Standard 3.5-inch display clearly shows all important vehicle information
- Option of steering control mounted on left armrest for greater forward visibility



Linde combi steering axle

Handling

- Outstanding manoeuvrability with twin motor front-wheel drive and combi steer axle
- High-performance synchronous reluctance motors for traction and lift
- Overhead tilt cylinders and torsion-resistant mast design for high residual load capacity
- Twin or single pedal control and Linde Load Control for precise operation
- Optional rear charging access for flexibility in operation

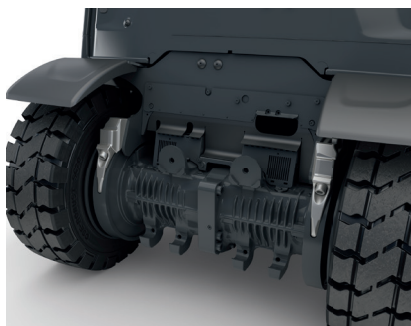

Easy to service

Service

- High vehicle uptime with long maintenance intervals, robust truck construction and wear-free components
- Remote software updates and error diagnostics enable preventative servicing and minimise downtime for servicing
- Fast maintenance and repair with to easily accessible service components and modular assemblies

For more information on Linde Material Handling equipment, please contact:



KION North America Corporation
2450 West 5th North Street, Summerville, SC 29483
Phone: (843) 875.8000 Truck Sales Fax: (843) 875.8471
Email: trucksales.na@kiongroup.com
www.kion-na.com

Linde Material Handling

Linde

Member of KION Group